



Adams County Regional Water District

9203 St. Rt. 136

P.O. Box 427

West Union, Ohio 45693

www.acrwd.com

Business Office: (937)544-2396 1-800-288-0039 (937)544-2668 Fax

Water Treatment Facility: (937)549-2339 1-800-252-3454 (937)549-2877 Fax

"Serving the Public Thirst"

2/14/17

Ohio EPA, SEDO
2195 Front Street
Logan, Ohio 43138
ATTN: Sarah Wallace

RE: LCR Mapping

Dear Ms. Wallace,

I am writing in response to HB 512 on the lead and copper rule. Adams County Regional Water District does not have any lead service lines in our system. We have always used either PVC or PE pipe for our service lines. I have included some records to show just that.

As most rural water districts and companies, we came into existence when USDA-RD (then called FHA) began funding these water purveyors in the late 1960's or early 1970's and still do today. Our district was formed in 1968 and began pumping water around late 1970 or early 1971. We feel that in this time period no lead service lines were used. We also feel that as a new entity and as new water taps were installed that most customers were running new service lines from the water tap to the house. As an employee of ACRWD for 30 years I do not ever recall seeing any lead service lines leading to a customer's house. All have been either PE or PVC.

I trust that this will help us meet the requirements set forth by Ohio EPA and the State of Ohio. If you require more information or action on our part please contact me at 937-544-2396 or Mr. Chris Hanson, plant supervisor, at 937-549-2339.

Sincerely,

Rickey W. Adamson
General Manager

Cc: board of trustees; Chris Hanson; Ohio Department of Health; Ohio Department of Jobs and Family Services; file

"Adams County Regional Water District is an equal opportunity provider and employer."

If you wish to file a Civil Rights program complaint of discrimination, complete the USDA Program Discrimination Complaint Form, found online at http://www.ascr.usda.gov/complaint_filing_cust.html, or at any USDA office, or call (866) 632-9992 to request the form. You may also write a letter containing all of the information requested in the form. Send your completed complaint form or letter to us by mail at U.S. Department of Agriculture, Director, Office of Adjudication, 1400 Independence Avenue, S.W., Washington, D.C. 20250-9410, by fax (202) 690-7442 or email at program.intake@usda.gov

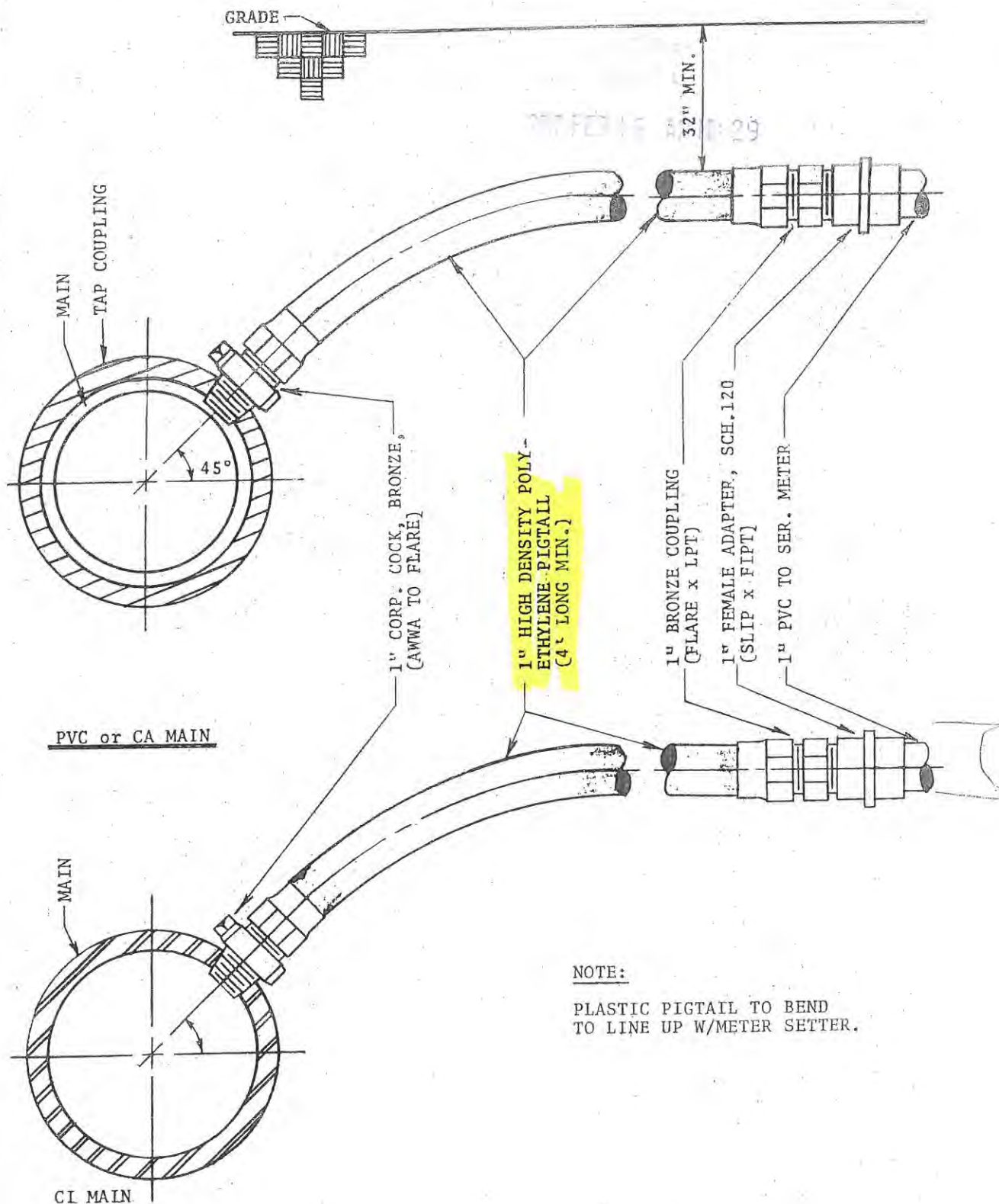

NOTE:
 PLASTIC PIGTAIL TO BEND
 TO LINE UP W/METER SETTER.

SERVICE TAP CONNECTION
 STANDARD DETAIL

From Phase I Division A-1
 Specification Book

SCDT. 25, 1969

SHT. NO. W-1A

TYPICAL FOR 5/8x3/4; 3/4" & 1" METER

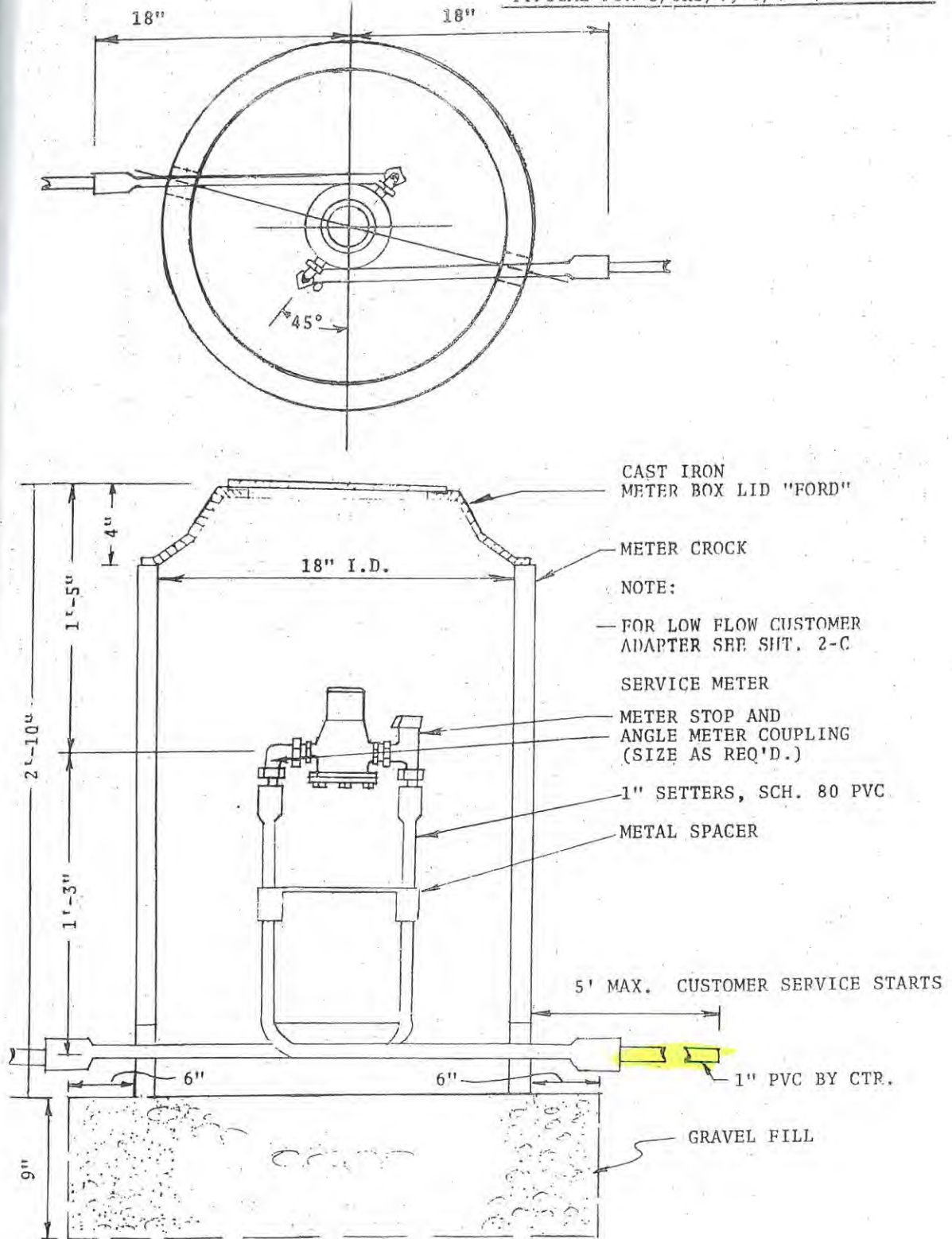

From PHASE F Division At SINGLE METER INSTALLATION
Specification Book Sept 25, 1969 STANDARD DETAIL

SHT. NO. W-2A

DAILY INSPECTION REPORT

CLIENT: Adams County Water Co., Inc.
Cherry Fork, Ohio

DATE 12-4-77
REPORT NO. 3 OF 3

PROJECT: Phase IV, Div. A. WORK LOCATION BURR CREEK RD.
CONTRACTOR: D.A.R. INC. LINE NO. A-14
SUBCONTRACTOR: GROOMS PLUMBING & ELEC. NO. OF MEN ON JOB 3
SUPERINTENDENT: GARY GROOMS EQUIPMENT ON JOB 1-2, 25
WEATHER: CLEAR & COOL 1-TRENCHER

WORK RECORD

CONTRACT ITEM	QUANTITY	STATION(S)	DESCRIPTION and COMMENTARY
20	126'	74+40±, 89+35±, 89+50±	1" IPS-PE.
27	3	74+40±, 89+35±, 89+50±	SERVICE TAPS
29-A	3	" " "	METER SETTER, CROCK, LIDS, TRAVEL
32-g	50'	74+40±, 89+35±	1" SERVICE BORE'S

Special Comments ¹ SERVICE LINE'S, TAP'S & RD. BORE'S FOR EDGAR WILLIAMS & BRUCE THATCHER. ² SERVICE BORE'S ARE 1-FOR EDGAR WILLIAMS & FOR BRUCE THATCHER.

Change Orders _____

Delays to work or Work Restraining Orders Issued _____

McCARTY ENGINEERING

by Kenneth Fite
(title) Resident Inspector

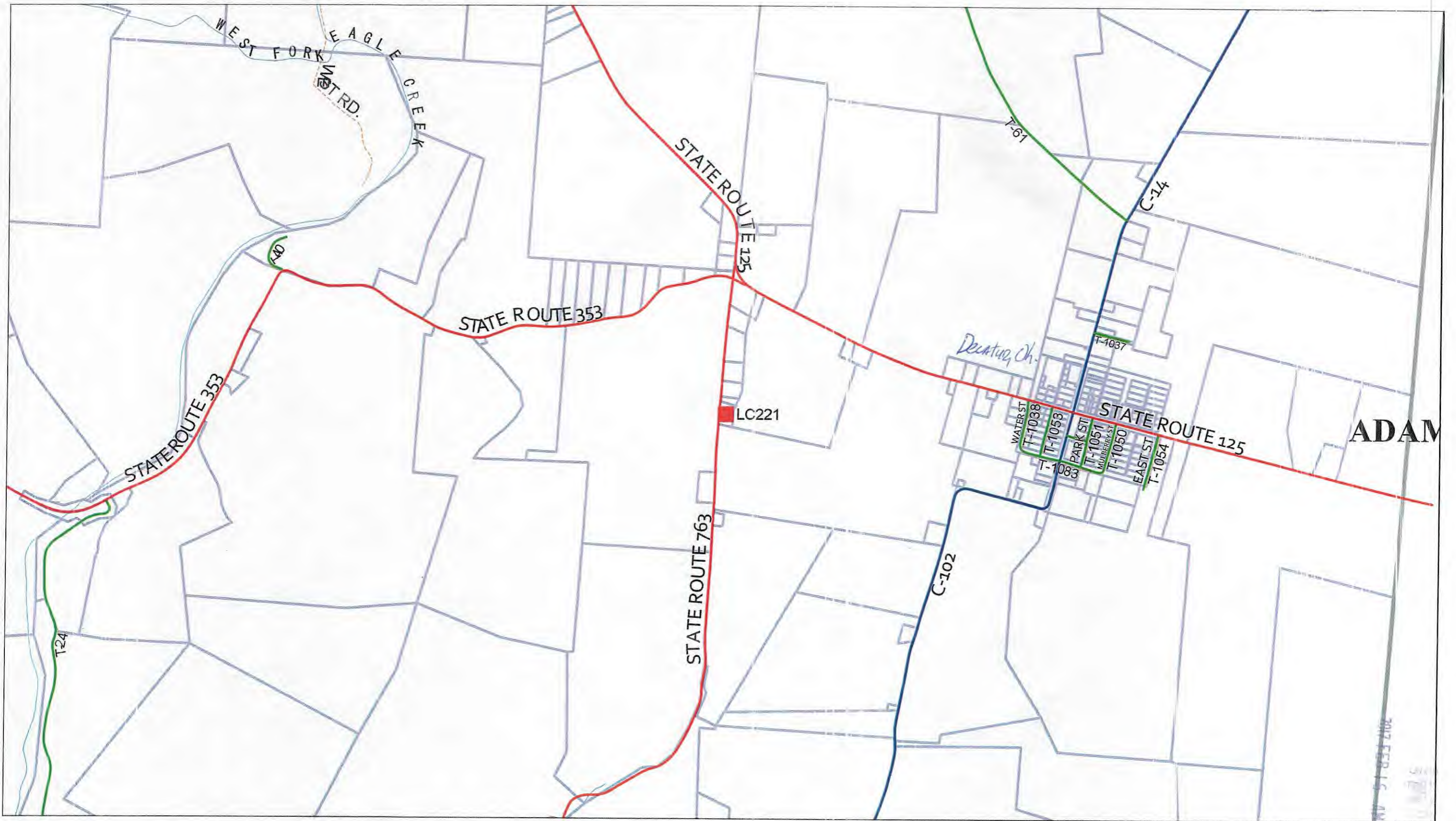

The materials available at this web site are for informational purposes only and do not constitute a legal document.

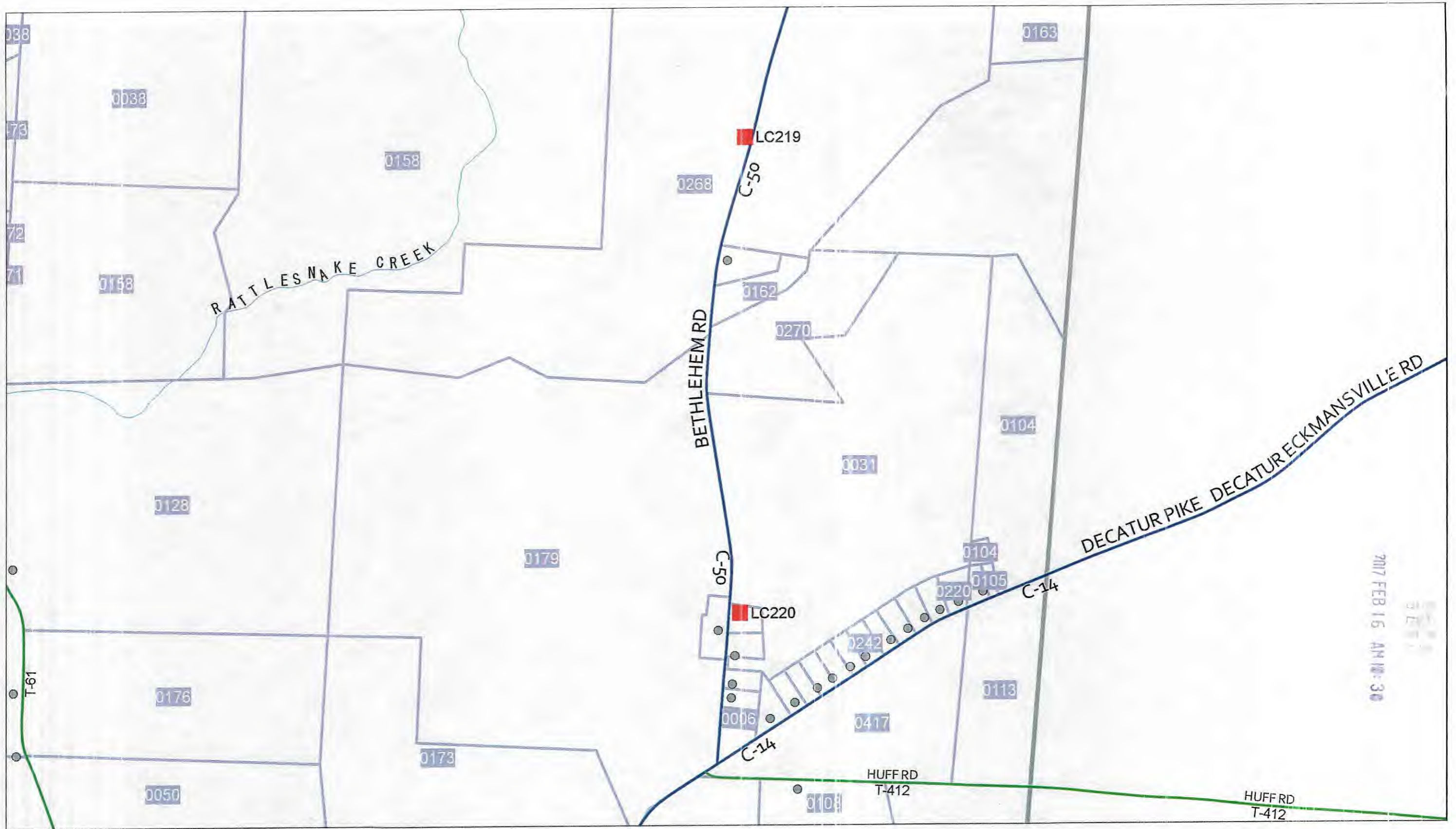

The materials available at this web site are for informational purposes only and do not constitute a legal document.

Brown County

2017 FEB 16 AM 10:29

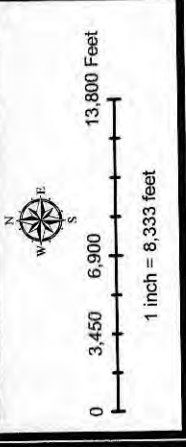
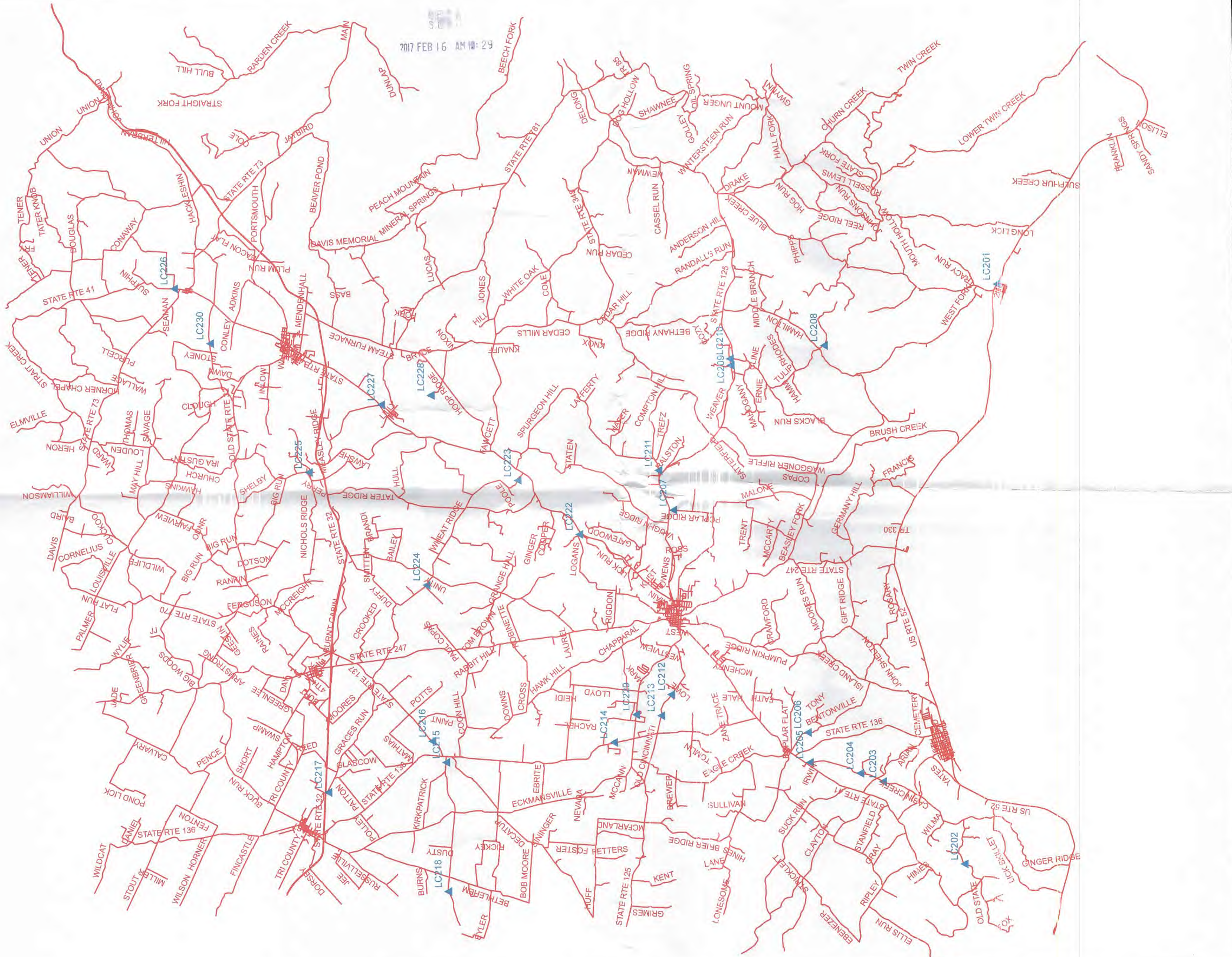

MAINTAINED BY:
 COUNTY ENGINEER'S OFFICE
 DAVID HOOK
 ADAMS COUNTY ENGINEER

PREPARED FOR:
 COUNTY AUDITOR'S OFFICE
 DAVID GIFFORD
 ADAMS COUNTY AUDITOR

NOTE: THIS APPRAISAL MAP
 IS FOR TAX PURPOSES ONLY.
 IT IS NOT INTENDED FOR
 CONVEYANCES, NOR IS IT
 A LEGAL SURVEY.

Legend
 ACW, SHPD
 Res/Cas/Ind/Ag